

# ENEMY OF THE PEOPLE

## TECHNICAL RIDER

Chile

Duration : 90 minutes.

### CONTACT

**PAULA PAVEZ, PRODUCER**

Email: paulipavezh@gmail.com

**JOSE MANUEL AGUIRRE, TECHNICAL DIRECTOR**

Email: elguilleaguirre@gmail.com

**LAURÈNE LEMAITRE , SCENOGRAPHER**

Email: LaureneLemaitre@gmail.com

**WEBSITE : [WWW.COLECTIVOZOOLOGICO.CL](http://WWW.COLECTIVOZOOLOGICO.CL)**

Number of people that go on tour : 11

---

1. SCENERY. (Furniture and props)
2. SOUND REQUIREMENTS
3. LIGHTING REQUIREMENTS
4. PROJECTIONS
5. WORKING SCHEDULE

## STAGE DIMENSIONS

	MINIMUM	IDEAL
Width	9 M	12 M
Length	7 M	10 M
Height	5 M	6 M

The organization must provide a black backdrop. No other drapes or curtains are required.

## SCENOGRAPHY DESCRIPTION

The scenography is a "box", mounted over wheels, that turns around its axis pushed by one of the actors. The back side of the "box" is made of wood panels. There is one door on it. The other three sides are made of steel frames painted in black.

Inside the "box" there is one table, four chairs, one sofa and one floor lamp. Hunged on the front side of the "box", there is a PVC curtain. Images are projected on the curtain.

Measurements of the "box"

WIDTH	4.88 m
DEPTH	2.44 m
HEIGHT	2.64 m

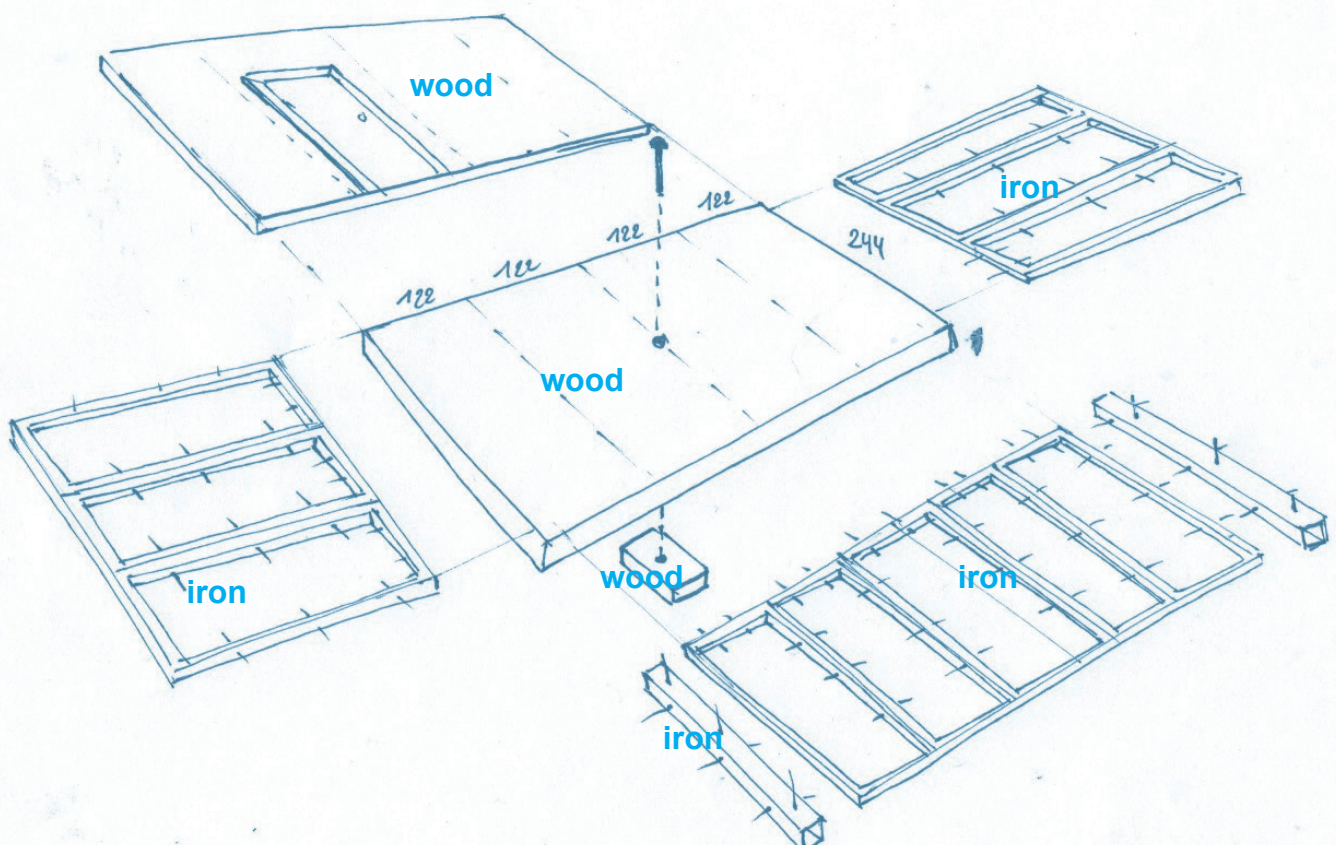

## SCENOGRAPHY

If it is not possible to set up the scenery as it is described above, the stage can be set up, keeping the proportions, as it follows:

One back wall made of wood panels.

2,44 meters in front of it, there must be a flying pipe that will be lifted up at one point of the performance.

The company provides the PVC curtain that will be hunged to the flying bar. The curtain weights 10 kilograms.

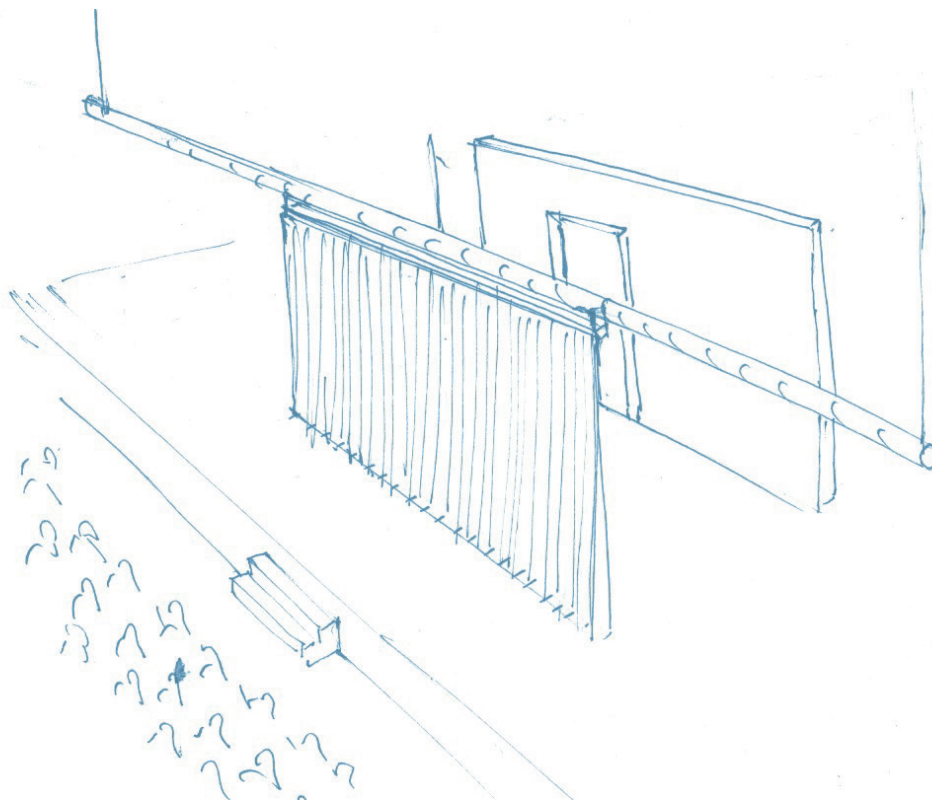

# UN ENEMIGO DEL PUEBLO - Colectivo Zoológico

Unid. de medidas compuesta de un panel de 2x1 (pulgadas) y de un panel de 2x1 (pulgadas)

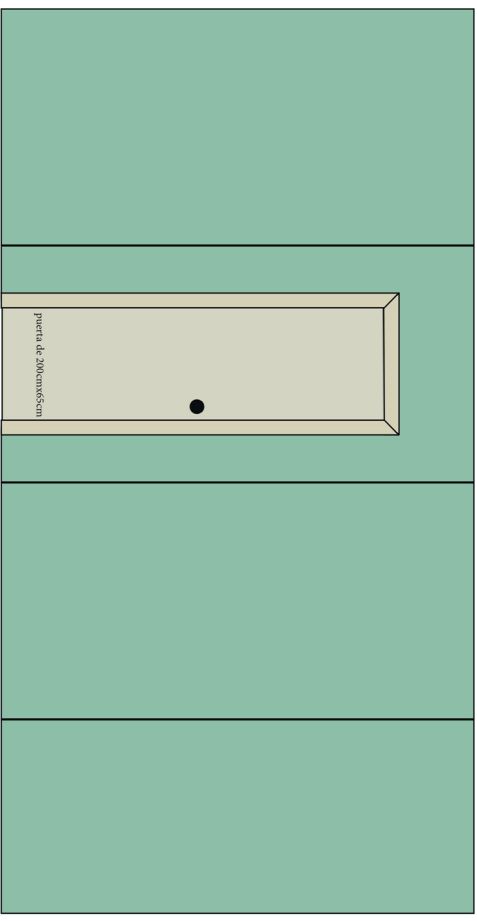
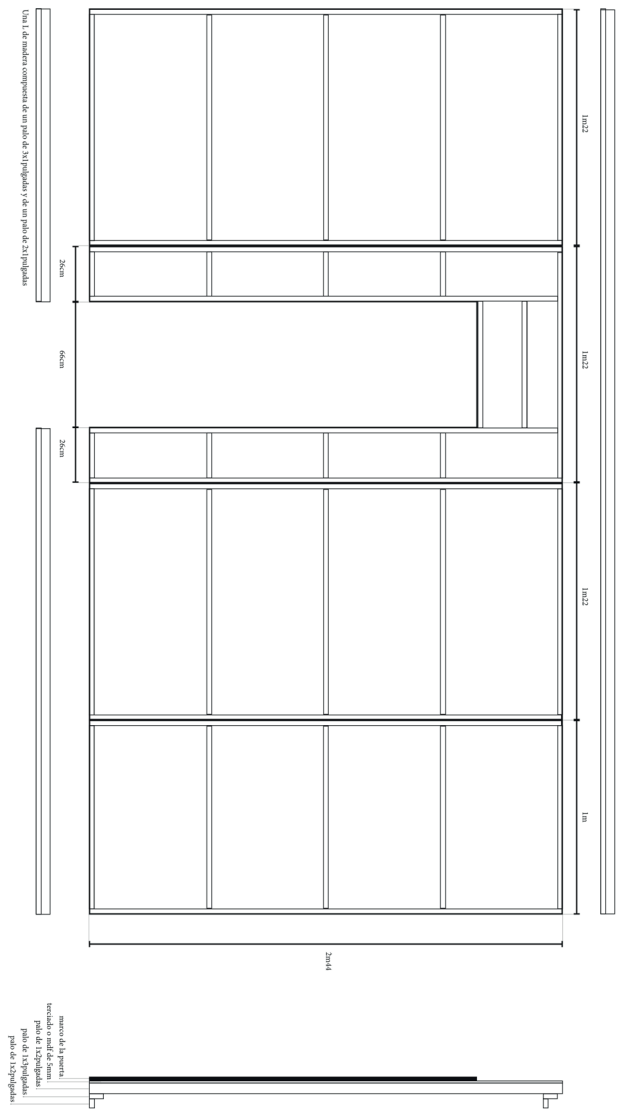

## FOTOS DE REFERENCIA



## DETAILS



## SCENOGRAPHY PROVIDED BY THE ORGANIZER

### Sofa:

The measures of the sofa must be very precise. It should be 100 cm to 120 cm wide, 80 cm depth and 90 cm. high.



Table  
120 cm x 80 cm.



"Fancy" seat.



Floor lamp.



4 black folding chairs.



2 chairs



1 fog machine

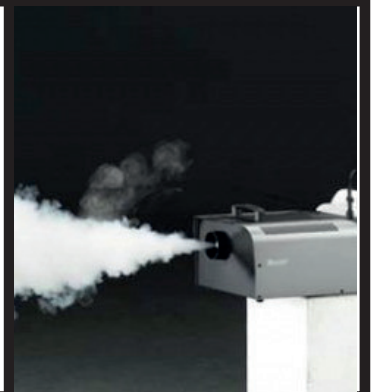

1 Beige Carpet (200 cm x 300 cm).



**PROPS PROVIDED BY THE ORGANIZER**

**Red plastic cups.**



**Small Teapot.**



**Glass Whisky Bottle.**



**3 Whisky glasses**



**1 Plastic Doll.**



**1 Arizona Tea Can.**



**1 simple Bouquet of flowers**



**1 Whisky flask.**



**3 small glasses**



**1 breakfast tray**



1 elegant Ashtray



1 Bicycle helmet for man



1 Bach flowers bottle.



1 elegant bread dish



4 diferents teacups



Bowl for chips



4 Bowl



- 1 bag of potato chips
- 1 bottle of Coke
- Jam
- 1 piece of bread
- 1 plastic garbage bag
- Empty plastic or glass bottles, empty bags of chips, etc.
- Tea bags.
- Paper napkins.
- Empty whisky bottle
- Electric water heater
- 1 lightbulb

## 2. SOUND REQUIREMENTS

3 ways audio system according to the venue proportions  
5 channel mono and 1 channel stereo audio console  
31 bands Stereo Graphic equalizer  
4 shotgun microphones Mekse Mkct-409 or similar  
1 dynamic microphone shure SM 58 or similar  
1 microphone stand

The sound of the play is controled by one crew member from a Mac Book Pro. The organization must provide the conection with the console.

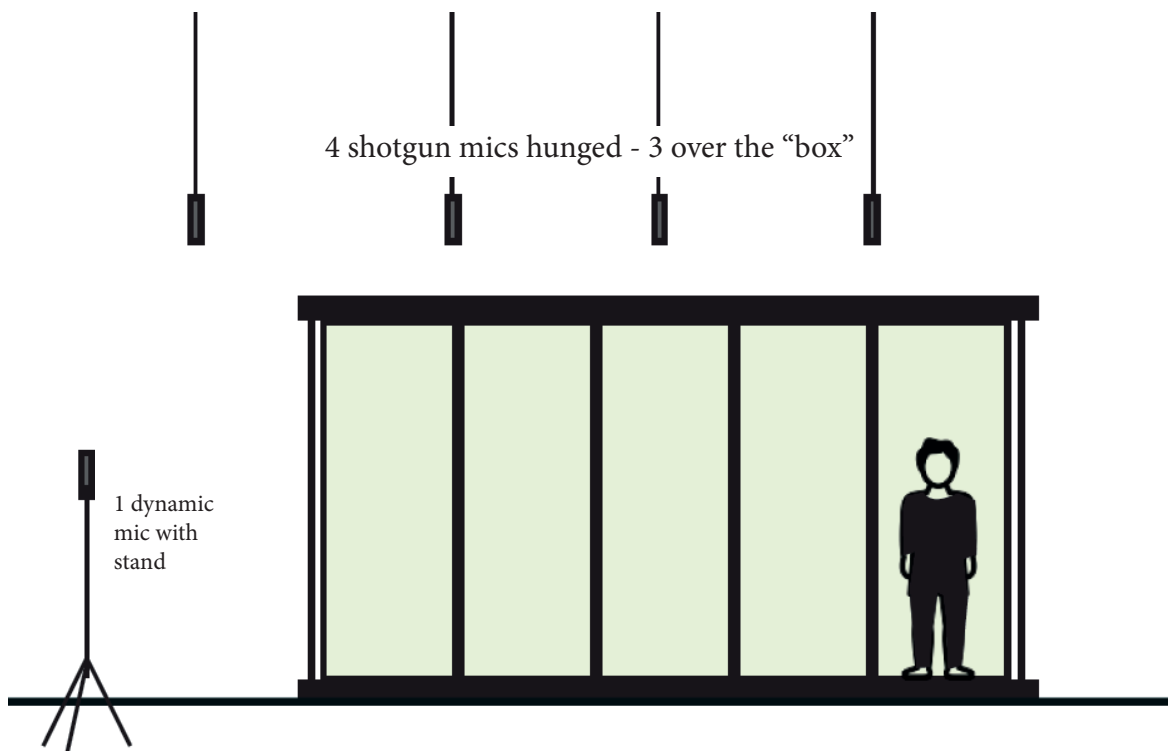

## 3. LIGHTS REQUIREMENTS

8 Fresnel 1000w with barndoor  
4 profiles 15°/30°  
4 profiles 25°/50°  
6 profiles 25°/50° 750w  
6 PAR 64 mfl 1000w  
24 dimmer channels 10°  
24 channel programable light console



# ENEMY OF THE PEOPLE

colectivo zoológico

Luis Alcalde

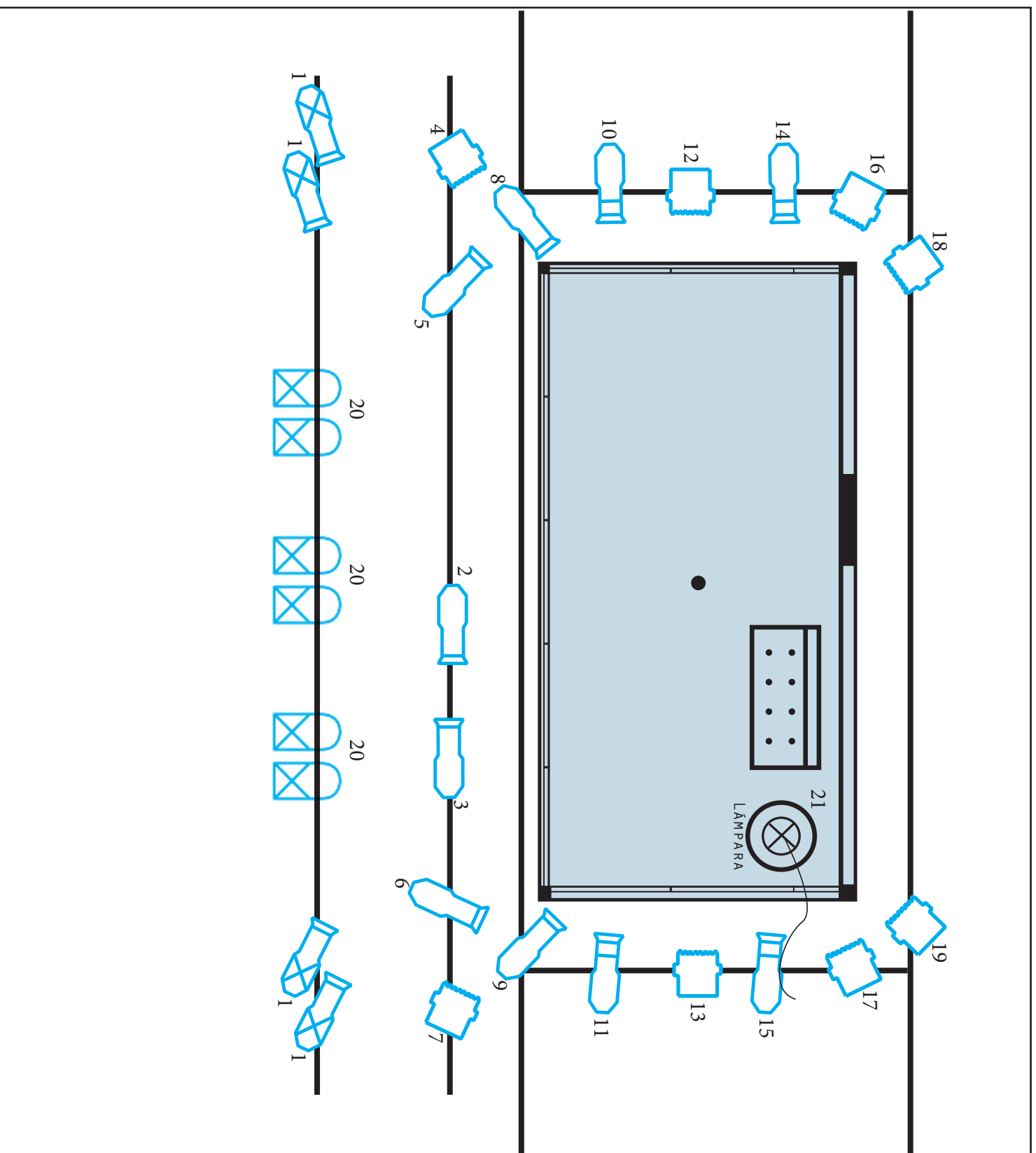

4 elips zoom 15/30

4 Elipsoidal zoom 25/50

6 elips zoom 25/50 jr

8 Fresnel 1000W

6 PAR 64 1000W.

floor lamp

## 4. VIDEO

The action of the play is captured by a crew member placed inside the "box", using a CANON VIXIA camera, and then projected into the PVC curtain.

The company provides the following elements for the closed caption tv system:

- 1 camera CANON VIXIA HFG30
- 1 MacBook Pro RETINA DISPLAY
- 1 Blackmagic Intensity Extreme CAPTURE CARD
- 1 PVC curtain 2,42 mts de height, 4,78 width
- HDMI VÍA cat6 signal extensor.

THE ORGANIZATION MUST PROVIDE:

- 1 PROJECTOR PANASONIC PT-DW740K OR SIMILAR
- HDMI connectivity from projector to video control booth

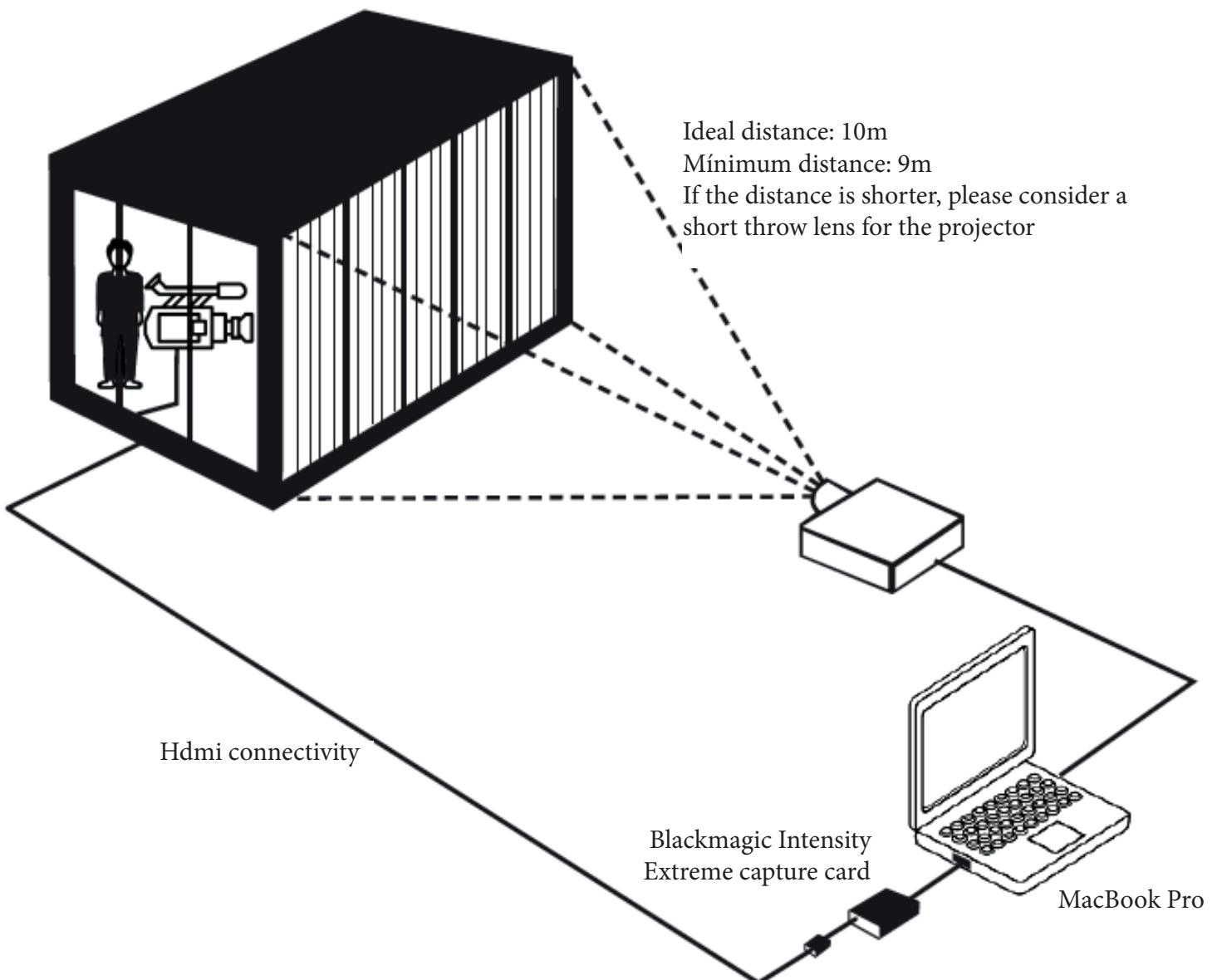

## 5. WORKING SCHEDULE

The set up takes two shifts of four hours.

The company members (eleven people) are in charge of the technical issues.

The organization must provide the presence of :

- 1 lighting technician
- 1 sound technician
- 1 video projection technician

### DAY 1

- 09:00 TO 14:00** - Load In
  - Scenography set-up
  - Lights rigginig
  - Sound set-up
  - Video set-up
- 14:00 TO 15:00** - Lunch
- 15:00 TO 20:00** - Lights focusing
  - Recording of show to the venue console
  - Sound Check
  - Video Check

### DAY 2

- 10:00 TO 14:00** - Technical rehearsal + corrections
- 14:00 TO 15:00** - Lunch
- 15:30 TO 17:30** - General rehearsal
- 17:30 TO 19:00** - technical corrections (if any)
- 19:00 TO 20:00** - Prepare stage for show
- 20:00 TO 21:40** - show
- 22:00 TO 23:00** - Strike out